



MULTI-SLIDE DOORS

INSTALLATION GUIDE & SITE PREPARATION



TABLE OF CONTENTS

- Site Preparation 3
- General Information..... 4
- Pre-Install Checklist..... 5
- Sill Pans & WRB..... 7
- Tools & Supplies..... 8
- Frame Prep and Assembly 9
- Panel Installation 11
- Adjustments 12

SITE PREPARATION ADVISORY

Loewen recommends a high level installer or someone that has been trained by Loewen to attempt a MultiSlide Install. MultiSlide Installations are complex and should not be attempted with simple written documentation.



Your Dealer or a certified Installer would be glad to review the entire instructions and familiarize you with this service instruction prior to installation in order to ease the process of preparation and installation.

2

NOTES:

This instruction assumes that exterior of building envelope is correctly prepared with weather resistant barriers – that meet local and state codes. All frame and sill surfaces must be correctly prepared for air and water and structural integrity by the builder or contractor before attempting installation.

It is recommended that Loewen Multi-Slide systems are installed with sufficient overhangs to aid in prevention of water or air infiltration that may contribute to structural damage to the surrounding area, finishes and/or systems.

Loewen offers installation and service through our dealer network.

GENERAL INFORMATION ON INSTALL

Note: The preparation of the rough opening for large openings such as those required by, but not limited to, LiftSlide, Bifold or Multi Slide doors have unique requirements.

Structural headers that allow for deflection no greater than 1/8" along the unsupported length once the header is fully loaded are required. Special care needs to be taken when installing any unit including transoms above such large opening units.

This manual is intended for construction professionals with proven competency installing doors for large openings. It is also recommended that certified installers are being used when installing this product.

This installation describes and recommends proper installation methods to ensure air, water and structural integrity will be maintained for maximum performance. During installation the Fit, Finish and Function will be critical to get it right the first time by making sure to perfectly level the sill and maintain a square opening.

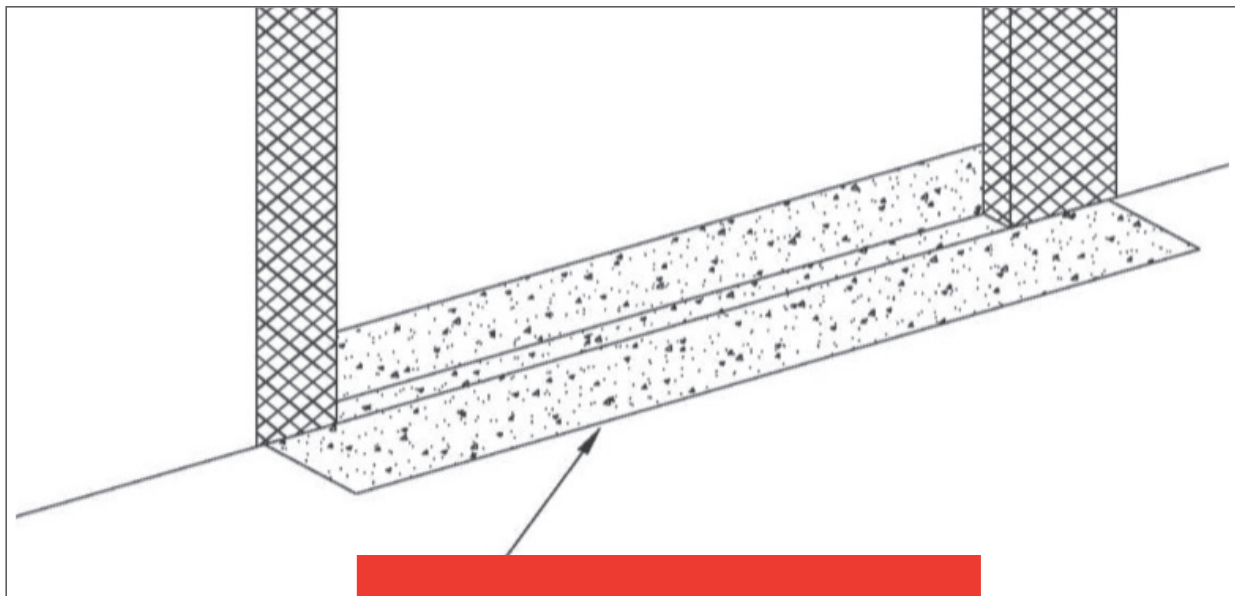
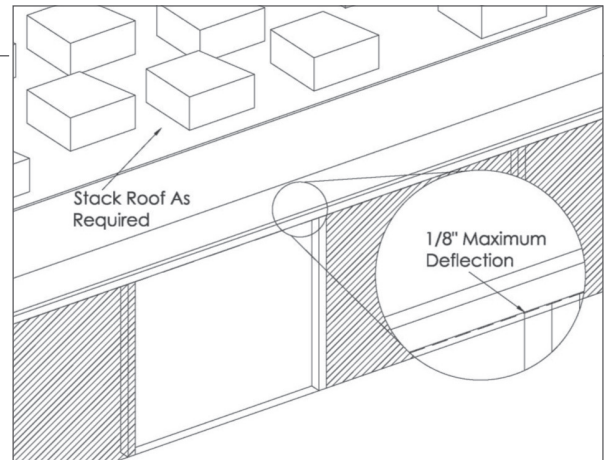

Sill Pans must be used in every installation of a Loewen MultiSlide system.

PRE-INSTALLATION CHECK LIST

YOU MUST WORK FROM THE PROVIDED DRAWINGS TO PREPARE THE OPENING

- The rough opening is the correct size, plumb and square. No sagging header. Take into account if the roof has been loaded or not. The maximum deflection over entire length of opening should not exceed 1/8" max. After the roof is loaded.
- Verify that the concrete or sub-floor where the system is to be installed is level. The frame system may be shimmed to compensate for an uneven floor but will adjust the relationship of the systems sill to the finished floor and may increase the overall height of the system in the opening. Any serious deflection in the concrete or sub-floor where the system is to be installed must be corrected prior to installation.
- It is important that your Framer knows the finished floor thickness to determine the header height.
- MultiSlide sills come in a variety of riser heights and should be noted as to the one specified for your application.
- The level of the finish floor needs to be determined ahead of time and noted somewhere near the opening.
- Exterior surface must have a negative slope from the sill assembly to allow water run-off from weep system (Recommend 2 degrees)

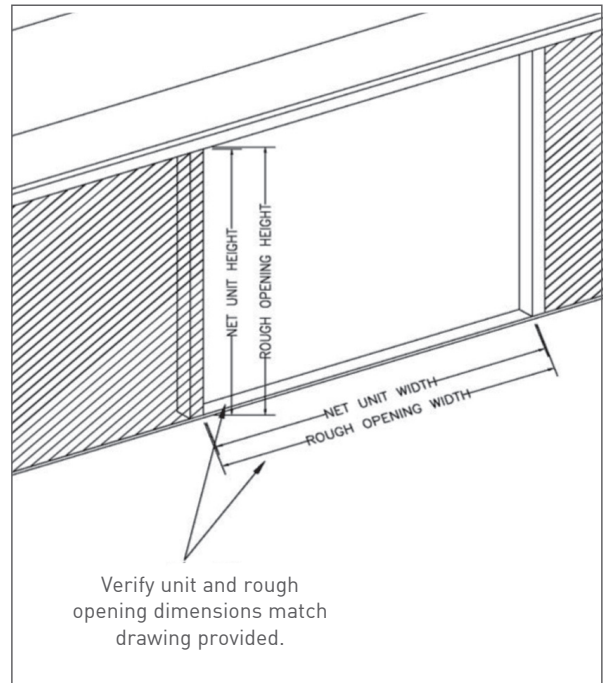

- Seal and Finish all the Panels and wood surfaces (specifically the edges) prior to installation, as it will be difficult to finish after the panels are installed. It also protects the wood from swelling and contracting, which can damage the wood itself and cause problems with operation.
- Once the doors are installed, it is difficult to access the overlapping stiles on the doors for any adjustment or finishing.
- Either wood framing or a continuous plane of plywood should be in place to anchor the head and/or side jamb.

POCKETING SYSTEMS:

Insure that the finished pocket width and depth is correct. These dimensions are referenced in your drawings. The outside wall of the pocket needs to be framed in and sheathed according to the building codes in your area.

Wait to build the interior pocket walls until after the installation of the doors. This will allow easier access to the exterior pocket walls for installation of the head and bottom track; easier installation of the panels once the head and bottom track have been installed.

A certain amount of the interior pocket wall surfaces will be visible so it is best to paint the interior surfaces black. Do this before the doors are permanently installed.

SILL PANS AND WRB

- Sill Pans can be rigid or flexible and are a highly recommended option to be used, sill pans are supplied by the contractor / builder.
- Pan flashing is used at the base of openings and designed to collect and drain water directly to the exterior or onto the weather resistive barrier.
- Sill Pans should be slightly sloped outward with a minimum 6" end dam, 1/2" interior upturn leg and 2" exterior down turn leg.
- Before fastening the rigid sill pan, apply three heavy 3/8" rounded bead of OSI Teq Seal onto the construction plate, one outboard, inboard and at the exterior down turned leg. Continue the sealant approx. 6" up both jambs at each end.
- Set the pan into the sealant and check for level. Secure the end dams with fasteners as required.
- Seal the end dams with sealant; tool the end dams to the framing
- **All installations must have a weather resistant barrier. WRB SHOULD BE APPLIED AND FASTENED PER MANUFACTURERS INSTRUCTIONS.**
- If WRB wrap is applied then cut away with a complete box cut of the opening.
- NO WRB should be brought into the rough opening.
- Cut back and expose the sheathing at the side jambs by removing approximately 1 1/2" of WRB. This will create direct-contact seal to the sheathing for flashing
- Flash the opening jambs and head with OSI TeQ Flash™ before the door is installed.
- Ensure that the flashing and the sill pans are properly overlapped and remain water resistant.



Flexible Sill Pan Installation



Rigid Sill Pan Installation

TOOLS AND SUPPLIES

1 TOOLS CHECK LIST

1. laser level
2. hammer
3. pry bars
4. ladders
5. utility knife
6. screw gun
7. applicator foam gun
8. "j" roller
9. tape measure
10. caulk gun
11. general tools

2 MATERIALS CHECK LIST

1. high impact slopped shims
2. screws
3. OSI Quad Sealant
4. OSI Flash or Henry Blue Skin
5. OSI or Great Stuff "PRO SERIES" Foam
6. rigid head flash
7. sill pan, rigid or flexible
8. optional liquid rubber "prosoco" sealer when applying sill into concrete

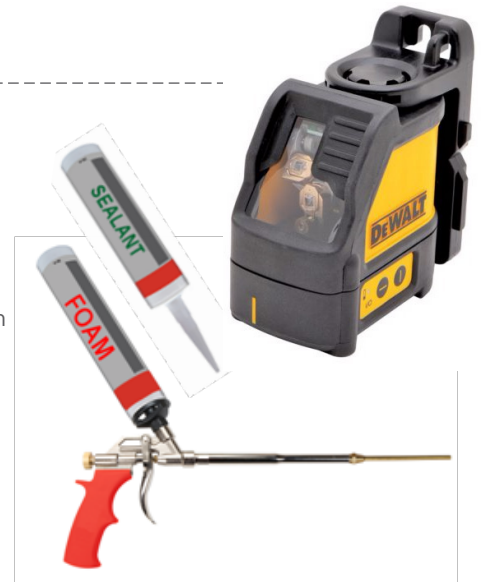

IMPORTANT NOTICES AND INFORMATION:

Read these instructions in their entirety prior to installing doors.
Contact Loewen at 1.800.563.9367 for clarification.

- Loewen is not responsible for site measurements nor the structural and architectural requirements for the installation of the Bifold door.
- Any local, regional or national building code requirements supersede these instructions.
- Building design, construction methods, building materials and site conditions unique to your project may require methods different from these instructions.
- Choosing the appropriate method is the responsibility of you, your architect, or your construction professional.
- Confirm with sealant/foam/barrier manufacturers that all materials used are compatible with one another.

FRAME PREP AND ASSEMBLY

1. Ensure you have the current version drawings before starting.
2. Verify the rough opening matches the RO dimensions on the drawing. Verify the finished floor thickness to determine the header height.
3. Set up the laser level into the center of the room and find the high spot, reference the sill from there.
4. Remove the screws from the lid on the plywood box; it will contain the bottom track, head track, jambs and accessories.
5. Lay frame head, sill and side jamb(s) on a flat surface. There are 3 sets of foam sealing pads to be applied
6. Apply foam sealing pads to ends of side jambs as shown and caulking to top and bottom of jamb legs. Once gaskets are in place, raise the frame head, sill and side jamb(s) on a flat surface with the exterior side up. **(And/or post interlock(s) for pocketing systems only)**
7. Align the left side jamb to the outside top left edge of the head. Attach the left side jamb to the head using screws supplied in the “Jamb Assembly” screw package. Repeat to attach right side jamb or post interlock.
8. Align left side jamb to the outside bottom left edge of the sill. Attach the left side jamb to sill using screws supplied in the screw package. Repeat step to attach right side jamb or post interlock.

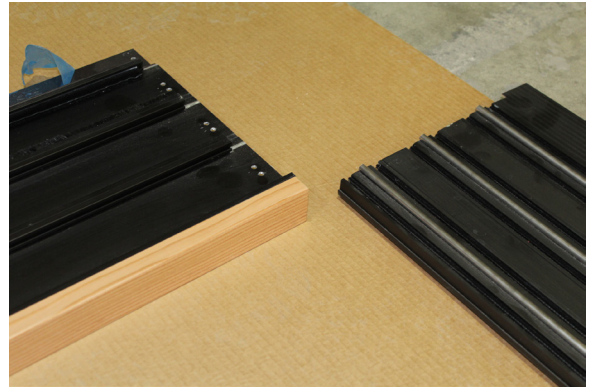

Lay frame head, sill and side jamb(s) on a flat surface

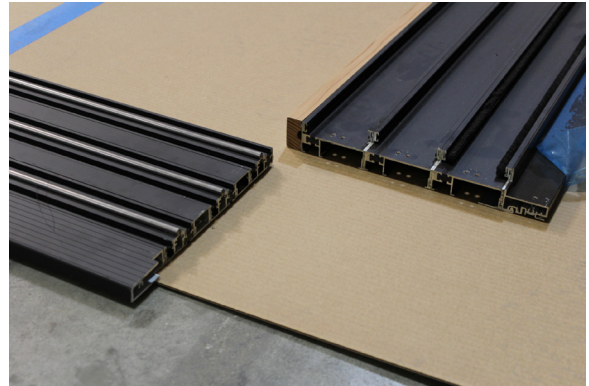

APPLY FOAM SEALING PADS & CAULKING

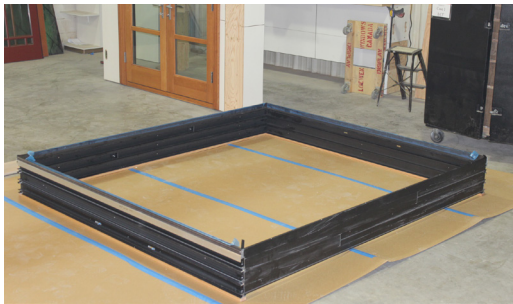
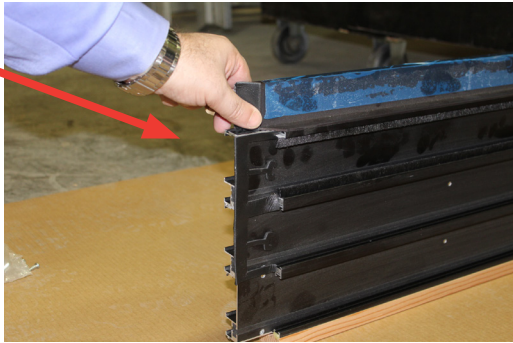
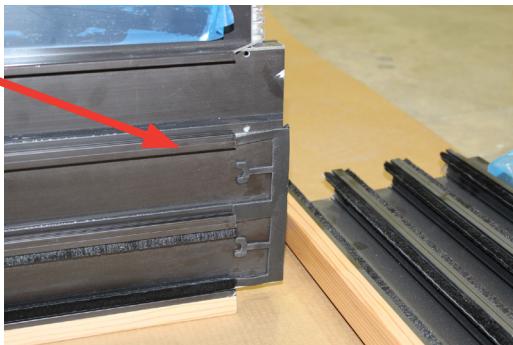
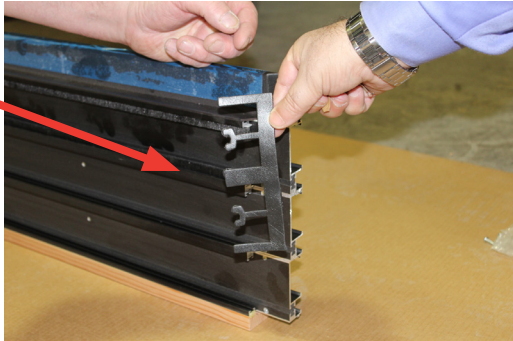
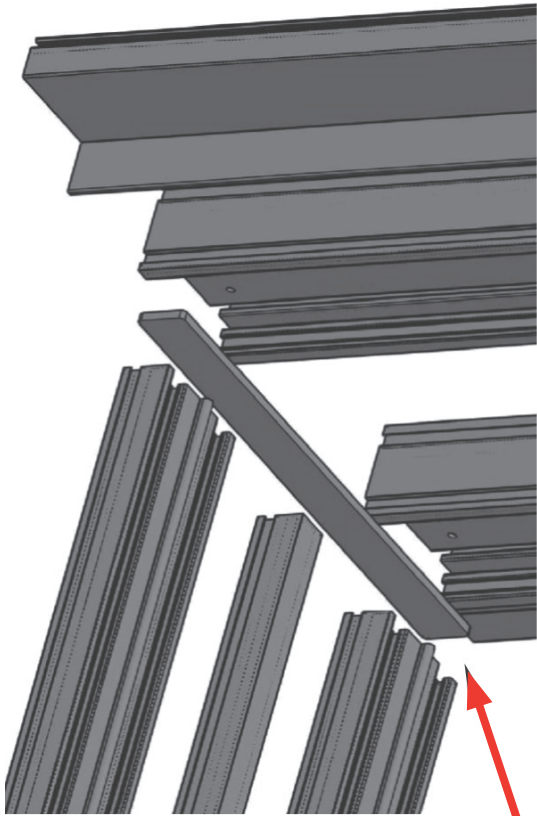

APPLY FOAM SEALING PADS & CAULKING

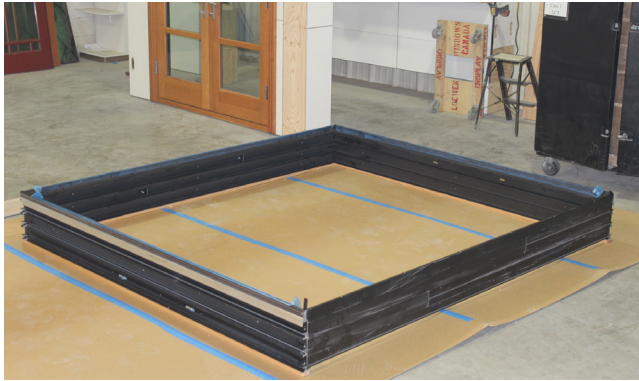

1. Align the left side jamb to the outside top left edge of the head. Attach the left side jamb to the head using screws supplied in the "Jamb Assembly" screw package. Repeat to attach right side jamb or post interlock.
2. Align left side jamb to the outside bottom left edge of the sill. Attach the left side jamb to sill using screws supplied in the "Jamb Assembly" screw package. Repeat step to attach right side jamb or post interlock.



Jamb Assembly screws

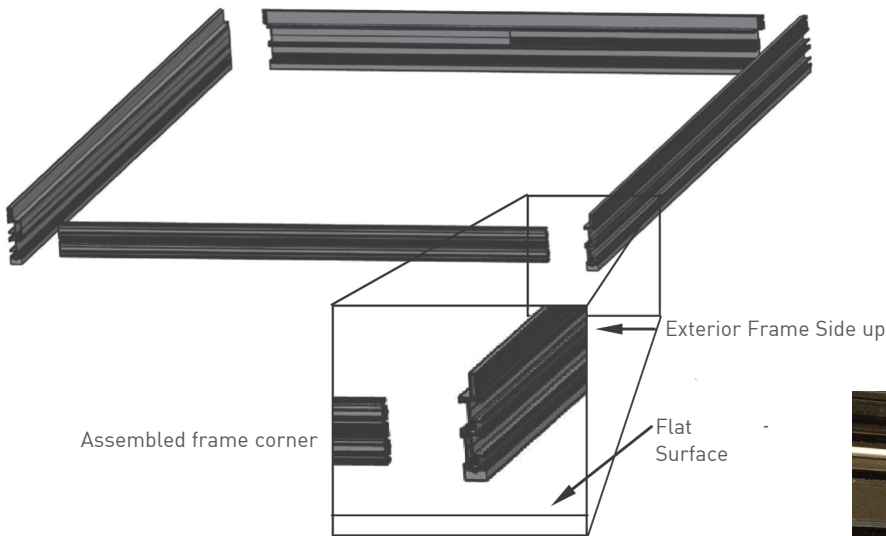

FRAME INSTALLATION

1. Stand assembled frame up and set in prepared opening. **Note: Unit is supplied with nail flange for RO placement and to provide additional water and air resistance, when installed with correct flashing and WRB application techniques.**
2. Drill concrete for anchor screws located in the sill install screw package through the factory pre-drilled holes located in the sill. Using a straight edge and/or level, verify that the sill is level and flat. Use shims as needed to level and flatten the sill. Attach using Tapcon masonry fasteners located in the sill install screw package.
3. Prior to attaching the head, square the frame to within the allowable tolerances. Using a straight edge and/or level, verify that the top track/head is level and flat.
4. Use shims as needed to level and flatten the head. Attach the head through the pre-drilled holes (Fill all screw holes with silicone bead) using the screws located in the head install screw package.
5. Using a straight edge and/or level, verify that the side jambs are level and flat. Use shims as needed to level and flatten the jambs. Attached the side jambs through the factory pre-drilled holes (Fill all screw holes with silicone bead) using the screws located in the jamb install screw package.
6. Cross measure the frame to confirm there is no variance larger than 3/16" per measurement and that the frame is square to within 1/8" horizontally and vertically
7. Fill all screw holes with silicone bead and apply all remaining screws into predrilled holes.
8. Appropriate rigid head flashing must be installed across the top of the unit. Secure the

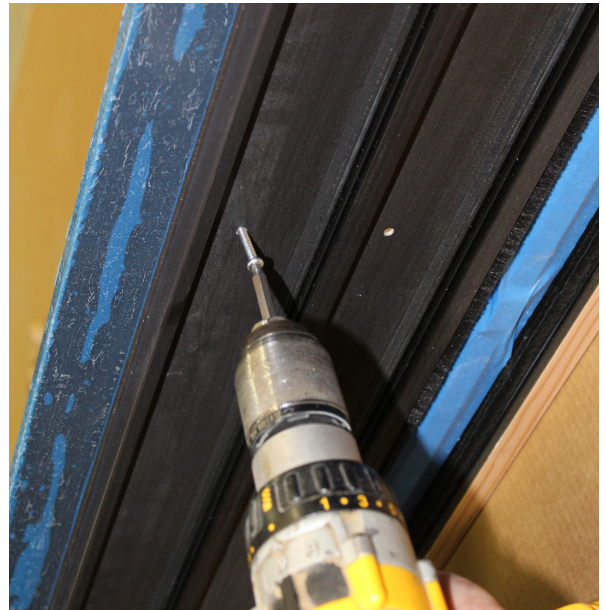

Head flashing with appropriate fasteners.
Seal over fasteners with Sealant.

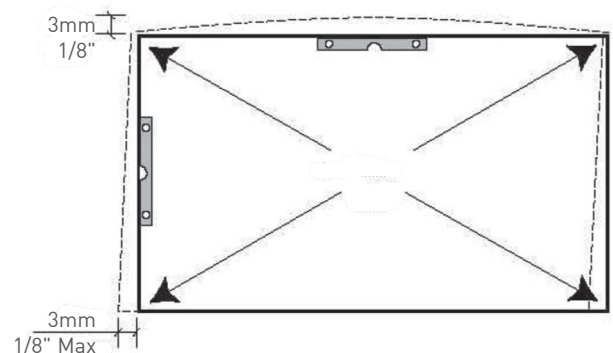
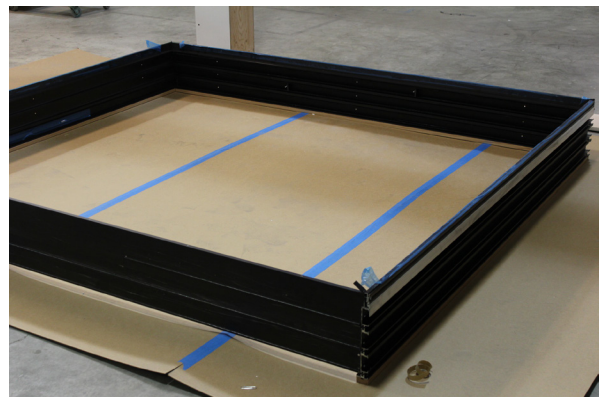

-
9. Interior seal: It is critical to fill the exterior 2" of the rough opening with low expansion foam. From the interior, insert the nozzle of the applicator into the rough opening, hold the tip of the nozzle 1" (25mm) back from the exterior nail flange and apply a minimum 2" (50mm) bead of foam into the rough opening on top and both sides.
 10. Check and re-check to make sure that the foam has made complete contact between the door and framing to both surfaces. Check Sill again to ensure no deflection.

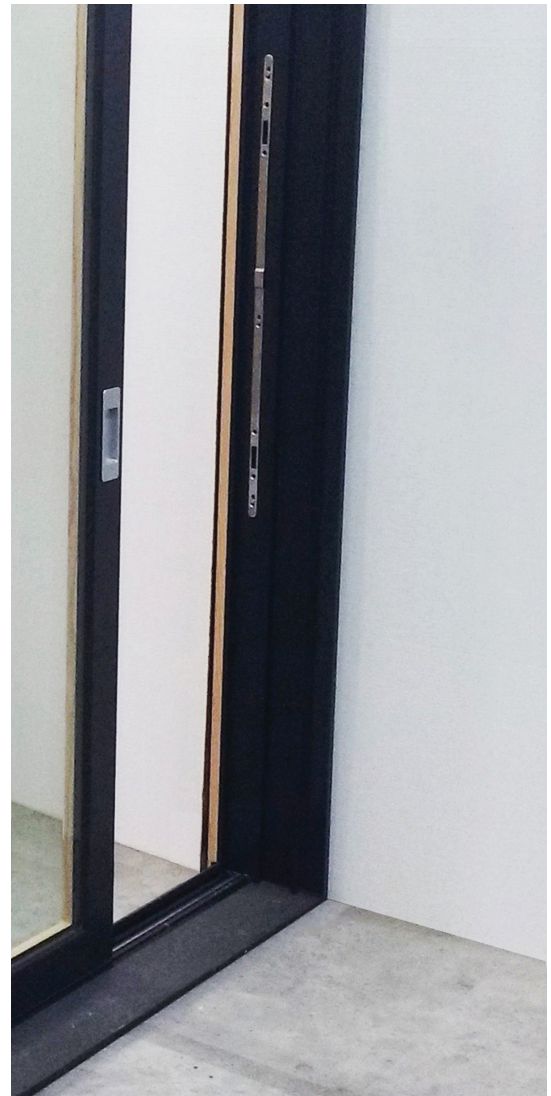

FINAL DOOR ASSEMBLY
(PANEL INSTALLED FOR REFERENCE ONLY)

PANEL INSTALLTION

1. Beginning with panel marked #1, holding the panel at an angle toward the head track, insert the top of the panel into the inner most head track and swing the bottom of the panel inward until it is parallel with the top and sits with the wheels on the corresponding sill.
2. Push panel #1 to the fixed panel jamb (for stacking systems) or into the pocket (for pocketing systems)
3. Repeat step for all remaining panels in sequential order.

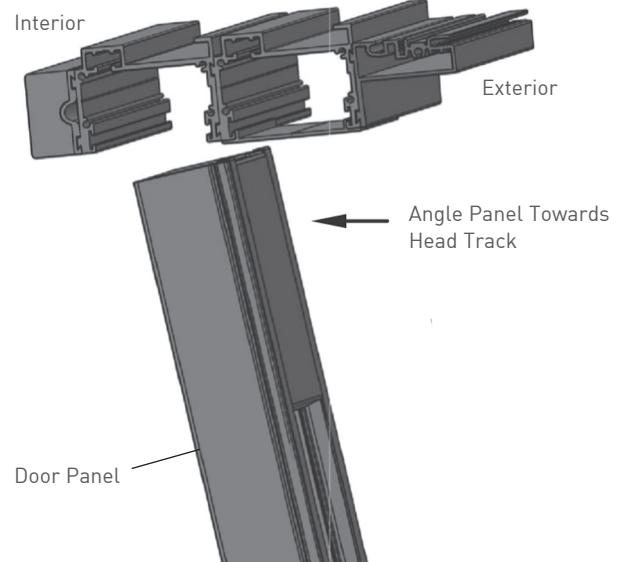
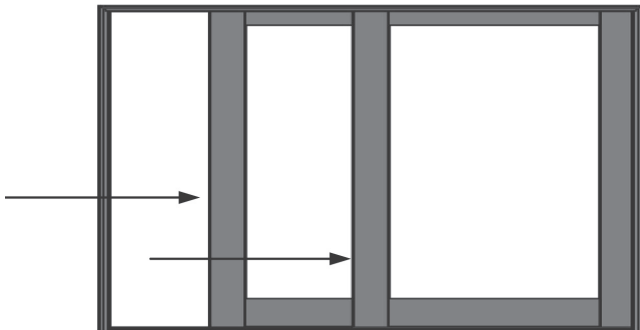

ADJUSTMENTS

1. Once all panels are installed, close the system and make sure all panel stiles line up properly by adjusting wheels for proper alignment.
2. Access to wheel adjustment through holes in bottom rail.
3. Wheel adjustments should be used for final tuning only. Once adjusted, tighten all wheels to the same approximate pressure to allow for even panel weight distribution.



Flush Handle

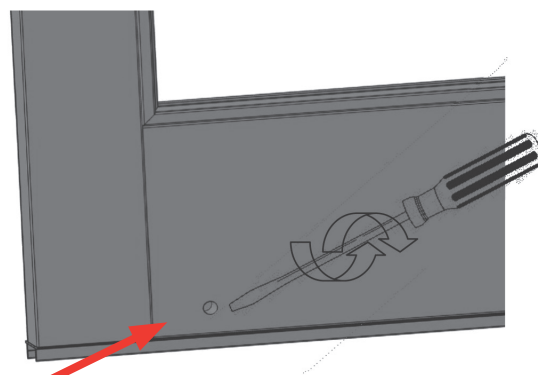

WHEEL ADJUSTMENT ACCESS HOLES



Glide Roller Assembly

INSTALLING HEAD TRACK COVERS AND SLIDE JAMB COVERS

Head track covers finish the look of the MultiSlide and provide a protective barrier to the exterior of the sliding tracks.

Header Track Panel stops need to be placed in each track where the head track covers will end. Location is easy to identify once all the door panels are closed. Use the pre-drilled holes to locate the correct positioning. Run sealant into the screw hole and attach stop.

The Track covers can now be installed by placing one edge in the header groove and tapping into place with a rubber mallet on opposite side.

Once the Headers are complete the side jamb covers can be installed. All side tracks will have a cover – except the final interior track (with strike plate)

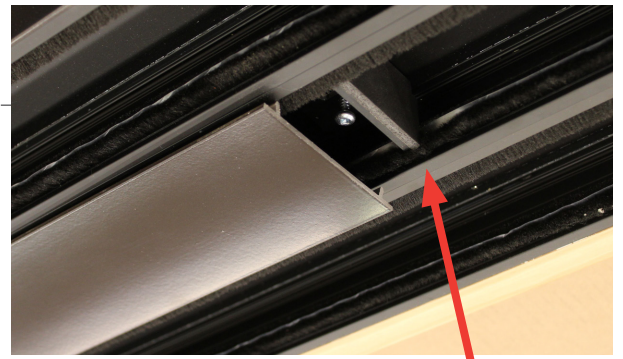

Panel Stops

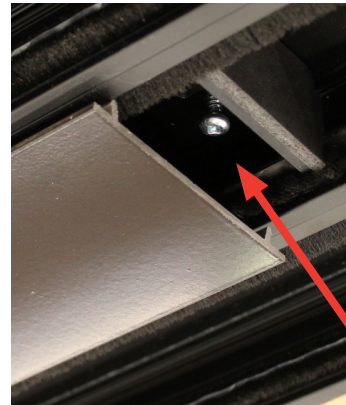

Head track cover will be installed after stops, shown for visual location only

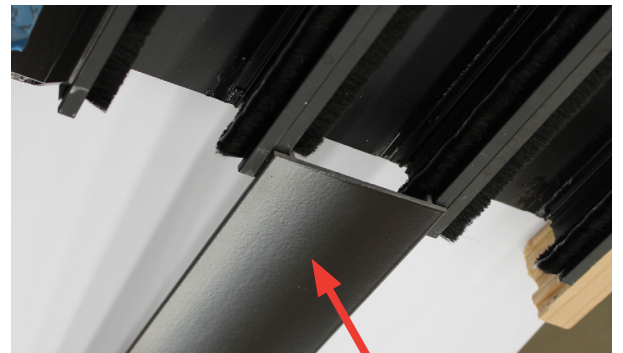

Track Cover

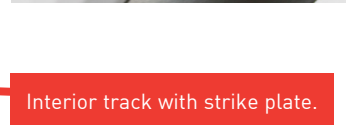

Interior track with strike plate.



FOLLOWER/POCKET CLOSURE INSTALLATION (FOR POCKETING SYSTEMS ONLY)

On Pocketing systems an aluminum follower extrusion is attached to the back of the final panel. This holds the Pocket Skirt Board to seal and finish the interior pocket opening when the door is completely closed. The width of board is dependent on the number of pocketing panels.

From interior side of system, attach the aluminum follower to the back edge of the last (exterior) panel with supplied Bolts Attach the wood pocket trim panel to the aluminum follower using the screws supplied.

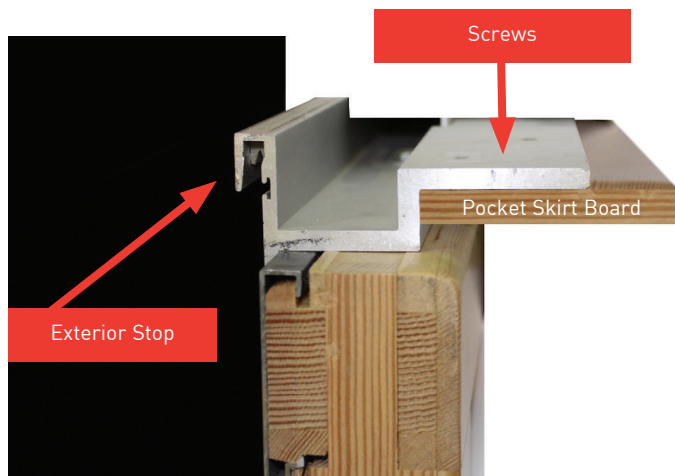

The notched bottom end of the aluminum follower will fit over the top of the sill nosing extensions when attached

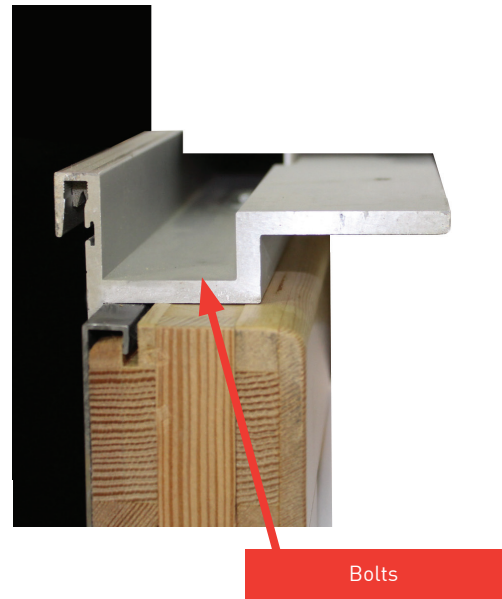

COLLECTOR INSTALLATION

On multiple panels systems, a collector strip is attached to additional panels. (Excluding first interior and final exterior panel) This is mounted to top of door and allows all panels to open and stack together. Attach with screws supplied after door finishing and sealant is completed.



SILL RISER OPTIONS

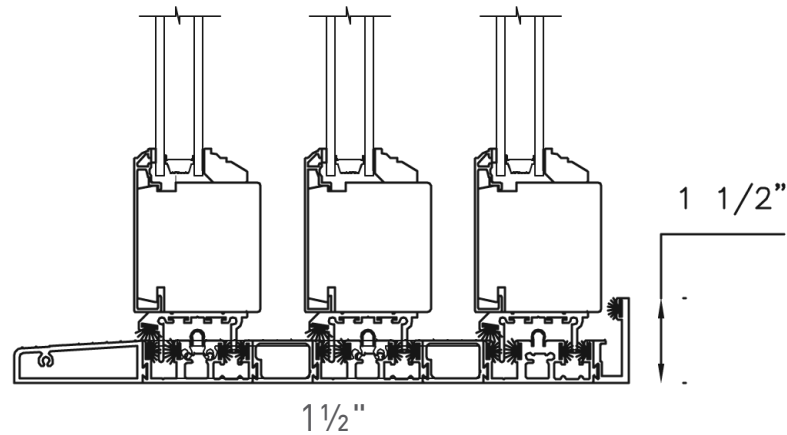
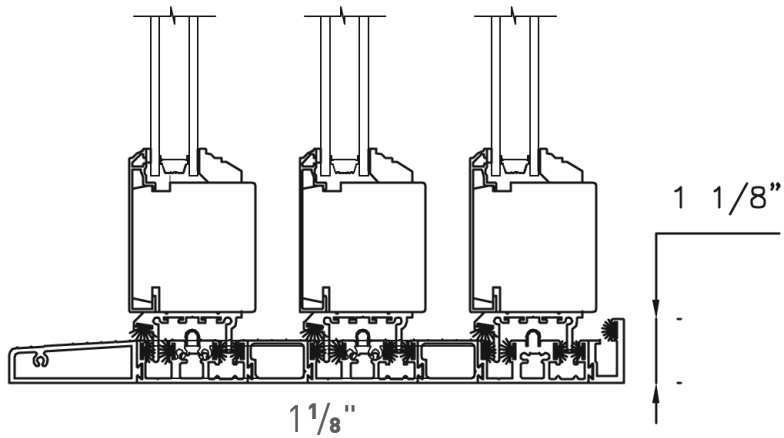
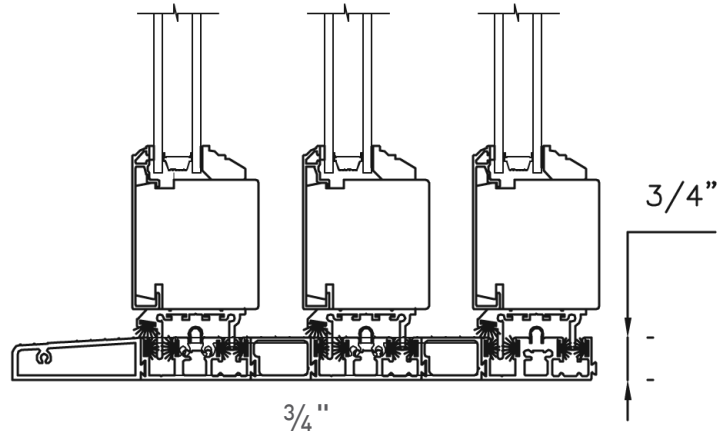

- Note:
- Drawings shown are typical details.
 - Additional sizes and configurations available.
 - Screen options may be available depending on size and configuration.
 - Raised threshold available with a maximum of 6 panels per sill [12 in a bi-parting configuration; 2 per track].
 - Consult your Authorized Dealer for details.
 - All dimensions to have +/- 1/16" [2 mm] tolerance.
 - O = Fixed
 - X = Operating
 - P = Pocketing

- The preparation of the rough opening for large openings such as those required by, but not limited to, LiftSlide, Bifold and MultiSlide doors have unique requirements. Structural headers that allow for deflection no greater than 1/8" along the unsupported length once the header is fully loaded are required. Special care needs to be taken when installing any unit including transoms above such large opening units.
- Loewen is not responsible for site measurements or the determination of structural and architectural requirements for the installation of large opening products such as but not limited to, Liftslide, Bifold and MultiSlide doors. Site specifications are the responsibility of building professionals or engineers to determine.

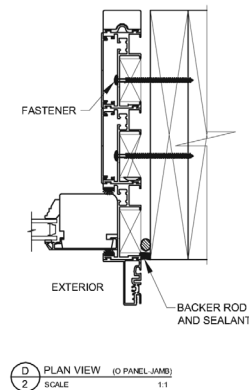
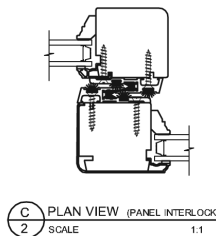
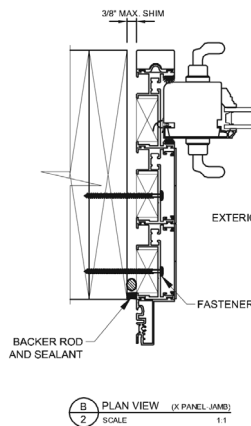
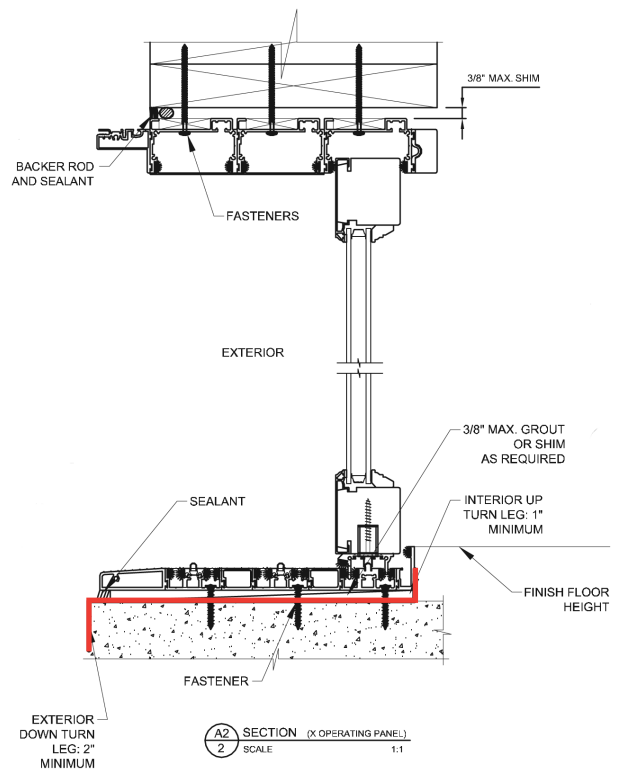
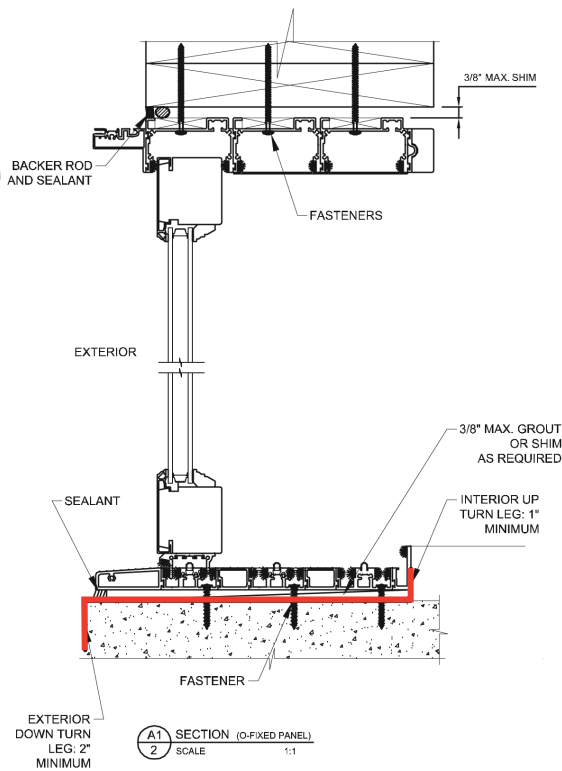

- Note:
- Drawings shown are typical details.
 - Additional sizes and configurations available.
 - Screen options may be available depending on size and configuration.
 - Raised threshold available with a maximum of 6 panels per sill [12 in a bi-parting configuration; 2 per track].
 - Consult your Authorized Dealer for details.
 - All dimensions to have +/- 1/16" [2 mm] tolerance.
 - O = Fixed
 - X = Operating
 - P = Pocketing

- The preparation of the rough opening for large openings such as those required by, but not limited to, LiftSlide, Bifold and MultiSlide doors have unique requirements. Structural headers that allow for deflection no greater than 1/8" along the unsupported length once the header is fully loaded are required. Special care needs to be taken when installing any unit including transoms above such large opening units.
- Loewen is not responsible for site measurements or the determination of structural and architectural requirements for the installation of large opening products such as but not limited to, Liftslide, Bifold and MultiSlide doors. Site specifications are the responsibility of building professionals or engineers to determine.

Loewen metal clad products carry the industry's best warranty, covering paint, glass and wood components for 20 years.
Visit loewen.com for complete details.



20 YEAR WARRANTY ON GLASS,
WOOD COMPONENTS & PAINT

**TO FIND YOUR NEAREST LOEWEN DEALER GO TO
WWW.LOEWEN.COM OR CONTACT US AT:**

service@loewen.com

1.800.563.9367

Information subject to change without notice.

Distributed by Loewen Inc. in the USA and C.P. Loewen Enterprises Ltd. in Canada and internationally.
Trade Marks owned by C.P. Loewen Enterprises Ltd. Used under license. © C.P. Loewen Enterprises Ltd.
All rights reserved.



Recycled Paper
Printed in Canada
P0000A_0517



www.loewen.com